

# LED SURFACE LIGHT

Product&Family Code: 016 077 0040

**HAZEL-40**



WHITE

BLACK

## Technical Data

Voltage (V)	160-265V
Product Wattage (W)	40
Equivalence with incandescent lamp	320
Colour Render Index (Ra)	>Ra80
Colour Temperature (K)	6400K
Materials	Plastic
Protection Class	II
Dimmable	No
EEL (Containing Product)	-
Warm-up time up to 60 % of the full light output	Instant Full Light
Luminous Flux (lm)	2800
Luminous Efficacy (lm/W)	70
Rated Life (hrs) ⌚	25.000
IP Rating	20
Power Factor	>0.5
Beam Angle	120°
Starting Time	<0.2s
Number of ON-OFF cycling	x15.000

## Technical Drawing

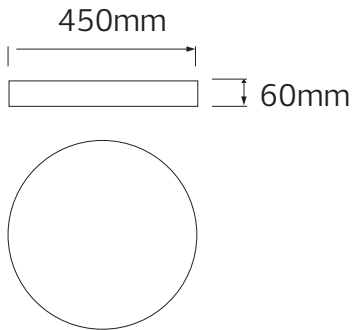

## Applications

- Airport, Bathroom, Bedroom, Car Park, Cinema, Gallery, Hospital, Hotel, Kitchen, Museum etc.



## Features

- High Lumen and CRI, Good quality & Constant Current driver.
- High heat dissipation, low carbon and environmental protection.
- SMD LED Lamp Base.

